

# WS22M

CLARK

CLARK introduces the WS22M powered drive straddle narrow aisle stacker for work positioning in tight areas

## FEATURES & BENEFITS

- **HYDRAULICS**

Lift cylinder is hard chrome. Permanent magnet pump motor and chrome plated lift cylinder provides smooth lifting and lowering. Pump unit includes DC motor, solenoid, and gear pump.

- **DRIVE**

24-Volt permanent magnet DC drive motor with rare earth neodymium magnets in-creases efficiency and duty cycle.

- **ELECTRICAL**

Travel control provides smooth step less travel. Quick disconnect power cut off and battery discharge indicator are standard equipment.

- **BRAKES**

Electronic neutral braking function provides smooth and safe control. Electro-magnetic disc brake provides safe and secure stops under all conditions.

- **TILLER ARM CONTROLS**

Offset steering arm provides excellent line of sight for operators. Right angle stacking in aisles as narrow as 60".

Travel, lift, and lower functions are located in the ergonomic operator handle. All operator controls are accessible without having to lift the hand from the handle.

Angle grips are designed to allow easy operation with either hand. Wrap around guard, reversing switch, thumb control, and horn are standard. Low mounted tiller arm offers excellent operator comfort and minimum steering effort.

- **FRAME AND MAST**

All steel construction welded rigid steel chassis for added durability. Adjustable forks on pin style carriage. Forks are adjustable from 8" ID to 27.5" OD. Standard fork is 42" long x 3.5" wide x 1.25" thick

Non-telescoping mono mast with single lifting chain, adjustable mast rollers. Chrome plated lift cylinder provides smooth lift/lower operation and long life.

Three-inch-wide adjustable straddle legs for ease of operation in racked aisles. Four position adjustment allows for preset outrigger dimensions to fit various sized pallets. Straddle leg inside dimension (ID) can be set at 38" to 50" in 4" increments.

Fully enclosed wheel guard and flush mounted axles prevent wheel and axle damage during normal use.

- **SERVICEABILITY**

Removable one-piece power head cover allows for easy maintenance.

- **OPTIONAL BATTERY UPGRADE**

85AH maintenance-free batteries available



CLARK

# SPECIFICATIONS

- **CAPACITY**

2200 lbs. at 24" Load Center

- **INTEGRAL BATTERY / CHARGER**

24-volt maintenance free batteries with direct connect 110A 110VAC plug-in automatic charger.  
(2)12V 65AH

- **SPEED**

Transistor travel controller

**TRAVEL**

Variable from 0 mph to 3.41 mph empty  
Variable from 0 mph to 2.5 mph loaded

- **LIFT**

Up to 33.5 fpm empty  
Up to 17.8 fpm loaded

- **LOWERING**

Up to 17.5 fpm empty  
Up to 17.6 fpm loaded

- **TIRES / WHEELS**

**DRIVE**

8.26" x 2.76" polyurethane

**STABILITY**

4" x 2" polyurethane

**DUAL LOAD**

(2) 4" x 2" polyurethane

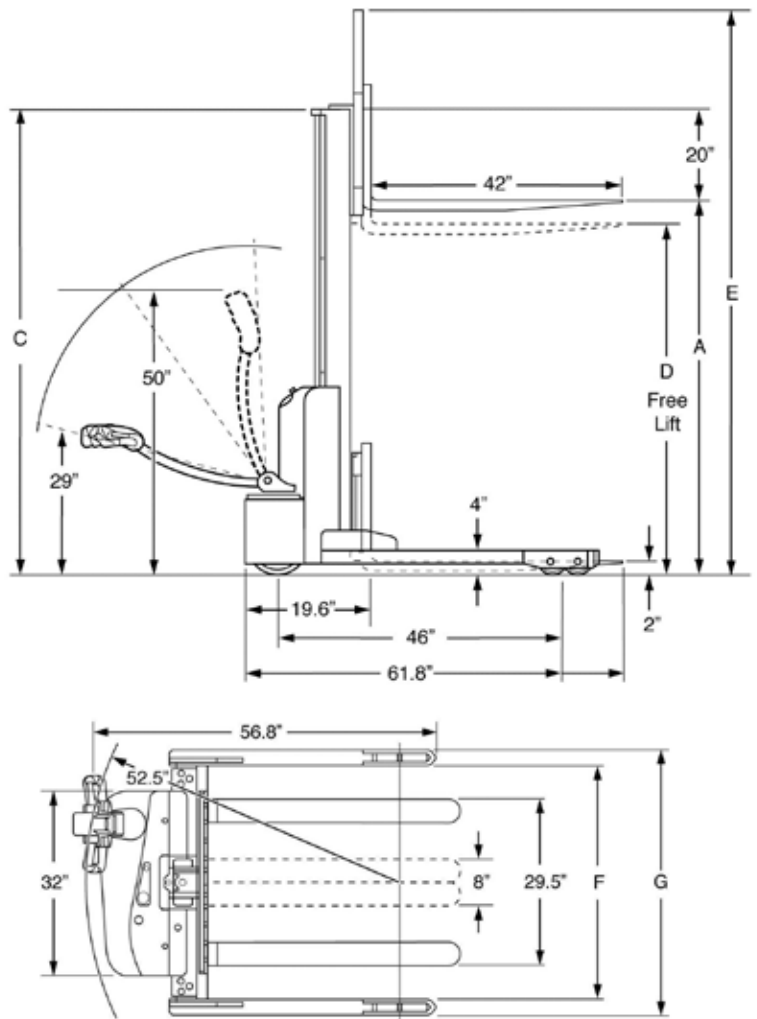

Dimensions								
Model	Mast	Lift height	Col Height	Free Lift	Ext Height w/LBR	Adjustable Straddle Leg 4" Increments	Adjustable Straddle Leg 4" Increments	Weight Complete
		A	C	D	E	ID-F	OD-G	
WS22M	Mono	62"	76.5"	56"	98.25"	38" to 50"	44" to 56"	1200 lbs

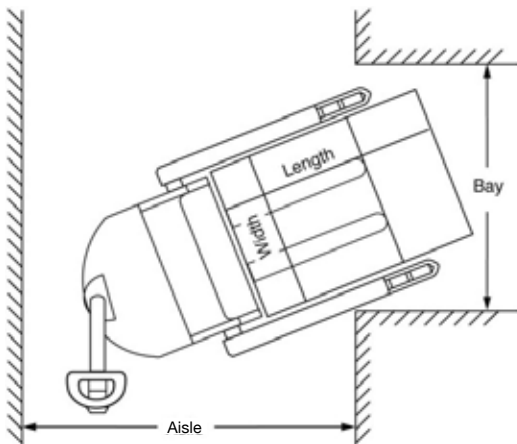

### Aisle Guide

WS22M Right Angle Stacking

Load Length			
Load Width	36"	40"	48"
36"	57.3"	57.3"	57.3"
40"	57.5"	58.6"	58.6"
48"	63"	63"	63"

For ease of use add 8" to aisle dimension listed

Aisle dimensions listed above assume the minimum bay width to be straddle OD plus 5" (2.5" on each either side of straddle leg). Straddle OD is the load width plus 8". Truck performance may vary due to application requirements and changes in model design.



**CLARK Material Handling Company**

North American Headquarters  
700 Enterprise Drive • Lexington, KY 40510  
866-252-5275 • [www.clarkmhc.com](http://www.clarkmhc.com)



59-894-0960