



# Heavy IC Forklift Truck

with capacities of 26,000 to 35,000lbs

*The World of Hangcha*



# Heavy IC Forklift Truck

Durable/  
Reliable/  
Economical/



## Drive Axle

/ Made in China, HANGCHA-customized, heavy-duty master reducer, pneumatic brake system.

## Transmission

/ Okamura Transmission, multi-stage torque converter, big converter ratio, wide range of auto-adjust speed; stable and smooth shift, 2 stage forward and 1 stage backward, easy operation and maintenance.

## Steering System

/ HANGCHA-made crosswise steering axle; The steering with load sensor and adjustable steering device make the operation easily.

## Hydraulic System

/ Multi-hydraulic valve make it easy to operate. Load sensor hydraulic system, dual pumps supply, dynamic load sensor priority valve, reduce power consumption, lower the hydraulic oil temperature.

## Chassis

/ The combined chassis structure provide the high intensity and low weight feature, increase the cooling area of the oil tank greatly.

## Power System

/ Cummins turbo 6 cylinder Engine is compliant with EPA Tier 4final Emission Regulation, high performance, low oil consumption, low speed with high torque, great capacity cooler.

## Brake System

/ Adopt auto parts, air braking system improves the comfort also reduce the pollution cause by oil leakage.

## Lifting Assembly

/ Wide view mast provide great operator visibility; Dual limited speed valves increase the safety; Distance between forks can be adjusted manually is the standard feature, customer can choose fork positioner or sideshifter.

## Overhead Guard

/ Full suspension overhead guard connected the chassis with 4 pivots using the rubber;Tilted structure is easy for maintenance; Smaller column and steering wheel increase the operator space.

## Electrical System

/ The instrument show all information about the forklift; it will sound alert when low brake pressure or non-lease parking brake.





## Standard Specification

- / Hour meter
- / Overhead guard
- / Full hydraulic power steering
- / Wide view duplex mast
- / Standard forks
- / Pneumatic tyre
- / Full Cabin
- / Air condition

## Options

- / 98.4-236.2" duplex mast
- / Special carriage and backrest
- / Solid tyre
- / Heater
- / Other dimension forks
- / Other attachment
- / Fire extinguisher
- / Suspension seat
- / Dual air cleaner or special air cleaner
- / Rear working light
- / Customer painting
- / Fork positioner
- / Joystick
- / Camera



# Heavy IC Forklift Truck

Distinguishing mark	1.1	Manufacturer	HANGCHA GROUP CO.,LTD.			
		1.2	Manufacturer's type designation	CPCD120-XW79	CPCD140-XW79	CPCD160-XW79
	1.3	Drive: electric (battery or mains), diesel, petrol, fuel gas	Diesel	Diesel	Diesel	
	1.4	Operator type: hand, pedestrian, standing, seated, order-picker	Seated	Seated	Seated	
	1.5	Rated capacity/rated load	Q (lb)	26000	30000	35000
	1.6	Load centre distance	c (in)	35	24	24
	1.8	Load distance, centre of drive axle to fork	x (in)	31	31	32
	1.9	Wheelbase	y (in)	122	122	122
Weight	2.1	Service Weight	lb	34392	38801	42329
Tyres, chassis	3.1	Tyres: solid rubber, superelastic, pneumatic, polyurethane		Pneumatic	Pneumatic	Pneumatic
	3.2	Tyre size, front		11.00-20-18PR	11.00-20-18PR	12.00-20-20PR
	3.3	Tyre size, rear		11.00-20-18PR	11.00-20-18PR	12.00-20-20PR
Dimensions	3.6	Tread, front	b <sub>10</sub> (in)	70	70	70
	3.7	Tread, rear	b <sub>11</sub> (in)	74	74	74
	4.1	Tilt of mast/fork carriage forward/backward	α/β(°)	6/12	6/12	6/12
	4.2	Height, mast lowered	h <sub>1</sub> (in)	129	129	129
	4.4	Lift	h <sub>3</sub> (in)	118	118	118
	4.7	Height of overhead guard (cabin)	h <sub>6</sub> (in)	120	120	121
	4.19	Overall length	l <sub>1</sub> (in)	245	245	249
	4.20	Length to face of forks	l <sub>2</sub> (in)	185	185	190
	4.21	Overall width	b <sub>1</sub> (in)	98	98	98
	4.22	Fork dimensions ISO 2331	s/e/l (in)	59x8x3.3	59x8x3.3	59x8x3.5
	4.25	Distance between fork-arms	b <sub>5</sub> (in)	20.5/86.6	20.5/86.6	20.5/86.6
	4.31	Ground clearance, laden, below mast	m <sub>1</sub> (in)	10	10	11
	4.32	Ground clearance, centre of wheelbase	m <sub>2</sub> (in)	13	13	14
4.35	Turning radius	W <sub>a</sub> (in)	171	171	175	
Performance Data	5.1	Travel speed, laden/unladen	km/h	13.7/16	13.7/16	14/16.8
	5.2	Lift speed, laden/unladen	m/s	63/-	63/-	63/-
	5.5	Drawbar pull, laden/unladen	N	22481/-	22481/-	22481/-
	5.7	Gradeability, laden/unladen	%	20/-	20/-	20/-
	5.10	Service brake		Pneumatic Drum	Pneumatic Drum	Pneumatic Drum
		Parking brake		Spring energy storage	Spring energy storage	Spring energy storage
Combustion-engine	7.1	Engine manufacturer/type		CUMMINS/QSB6.7	CUMMINS/QSB6.7	CUMMINS/QSB6.7
		Emission STD		Stage4/Tier4f	Stage4/Tier4f	Stage4/Tier4f
	7.2	Engine power according to DIN ISO 1585	HP	212	212	212
	7.3	Rated speed	r/min	2100	2100	2100
	7.4	Number of cylinders/displacement	(-)/(in <sup>3</sup> )	6/408	6/408	6/408
	7.10	Battery voltage/nominal capacity	V/Ah	2x12/120	2x12/120	2x12/120
		Rated torque	bf.ft/r/min	620/1500	620/1500	620/1500
		Bore x stroke	(in)	4.2x4.8	4.2x4.8	4.2x4.8
	Stage FWD/RVS		2/1	2/1	2/1	
Addition data	10.1	Operating pressure for attachments	bar	200	200	200

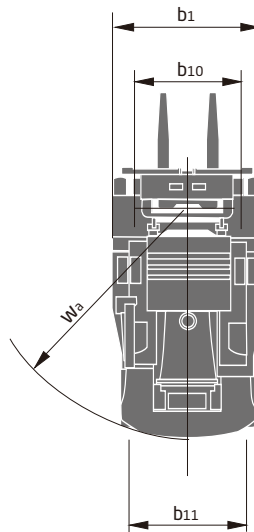
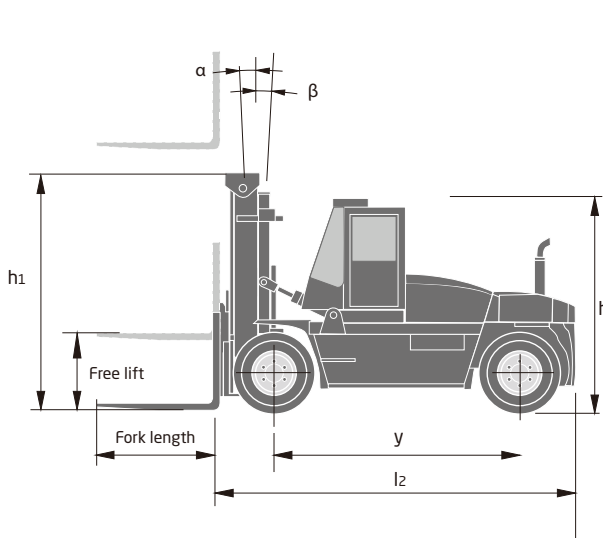

## LOAD CHART

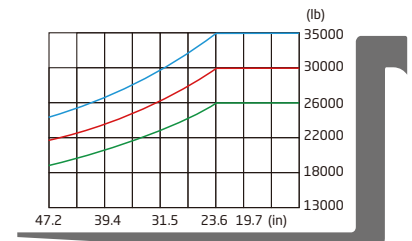

# 26000-35000lbs forklift mast specification

Type	Model	Mast fork height	Overall height		Load distance, centre of drive axle to fork	Tilt range		Capacity	
			Lowered	Extended		FWD	RWD	load capacity at 24 inch	load capacity at 35 inch
				Without backrest				Double tire	Double tire
		in	in	in	in	(°)	(°)	lb	lb
GX120MX (26000lbs)	GX120M300	118	125	185	29.9	6	12	26455	/
	GX120M330	130	131	197	29.9	6	12	26455	/
	GX120M360	142	137	208	29.9	6	12	26455	/
	GX120M400	157	145	224	29.9	6	12	26455	/
	GX120M430	169	153	237	29.9	6	6	26455	/
	GX120M450	177	157	245	29.9	6	6	26455	/
	GX120M480	189	163	257	29.9	6	6	26455	/
	GX120M500	197	167	265	29.9	6	6	26455	/
	GX120M550	217	178	287	29.9	3	6	22046	/
GX120M600	236	188	306	29.9	3	6	19841	/	
GX140MX (30000lbs)	GX140M300	118	129	188	30.9	6	12	30865	26455
	GX140M330	130	135	200	30.9	6	12	30865	26455
	GX140M360	142	141	211	30.9	6	12	30865	26455
	GX140M400	157	148	227	30.9	6	12	30865	26455
	GX140M430	169	156	241	30.9	6	12	30865	26455
	GX140M450	177	160	249	30.9	6	12	30865	26455
	GX140M480	189	166	261	30.9	6	6	30865	26455
	GX140M500	197	170	269	30.9	6	6	30865	26455
	GX140M550	217	182	290	30.9	3	6	26455	22046
GX140M600	236	192	310	30.9	3	6	24251	19842	
GX160MX (35000lbs)	GX160M300	118	130	189	31.7	6	12	35274	/
	GX160M330	130	135	200	31.7	6	12	35274	/
	GX160M360	142	141	212	31.7	6	12	35274	/
	GX160M400	157	149	228	31.7	6	12	35274	/
	GX160M430	169	157	242	31.7	6	12	35274	/
	GX160M450	177	161	250	31.7	6	12	35274	/
	GX160M480	189	167	261	31.7	6	6	35274	/
	GX160M500	197	171	269	31.7	6	6	35274	/
	GX160M550	217	183	291	31.7	3	6	30865	/
GX160M600	236	193	311	31.7	3	6	27558	/	



## HC FORKLIFT AMERICA CORPORATION

**Company address:**  
10405-A Granite Street Charlotte,  
NC 28273

Toll Free: 888-652-8395  
Phone: 980-888-8335  
Fax: 980-888-8336

america@hcforklift.com  
www.hcforkliftamerica.com



Follow us on Facebook



Follow us on YouTube



Follow us on WeChat

HANGCHA GROUP CO., LTD. reserves the right to make any changes without notice concerning colors, equipment, or specifications detailed in this brochure, or to discontinue individual models. The colors of trucks, delivered may differ slightly from those in brochures.